

100%
Swadeshi



ACE
Front End Loader

**Factory Fitted
Front End Loader**



- Heavy duty front axle
- Long life clutch (cerametallic)
- Ready for work from 1st day of purchase
- 4 Cylinder heavy duty engine with high torque
- Low diesel consumption
- ACE Ki Warranty
- 360° operator visibility
- 4 D positional valve (Joystick) Mechanism for enhanced operator comfort

TECHNICAL SPECIFICATION

Chetak DI 65 with Front End Loader

Engine	
Engine Make	ACE
Engine Model	A50 HT
HP/kW	50/36.9
No. of cylinders	4
Aspiration	Natural Aspirated
Bore/Stroke (mm)	105/118
Cubic capacity (cc)	4088
Rated RPM	2200
Air cleaner	Dry Air cleaner with Clogging Sensor
Max Torque (Nm @ RPM)	245 @ 1300
TRANSMISSION	
Drive	2WD
Clutch	Dual Clutch Friction plate with 7 pads Cerametallic
Gear Box	8F + 2R
Transmission Type	Constant Mesh
STEERING	
Steering	Power Steering
TYRE	
Front	7.50 x 16 LT (Loader Special)
Rear	16.9 x 28
Speed Forward	
Speed (Km/h) @ rpm	2.3-34@2200
Reverse Speed	3.00-12@2200

Hydraulic Pump High Flow (Tendam Pump) cc	35
Front Axle	Heavy Duty
Front End Loader	
(l) Maximum Operating Height in mm	4200
(j) Load Over height in mm	3570
(k) Pin Height in mm	3580
(l) Dump Height in mm	2690
(m) Reach at ground in mm	1980
(n) Reach at full dump in mm	630
(o) Roll back at round in degree	50
(p) Dump Angle in degree	45
Bucket Volume capacity in cu.m.	0.60
Safe working Load in kg (min)	750

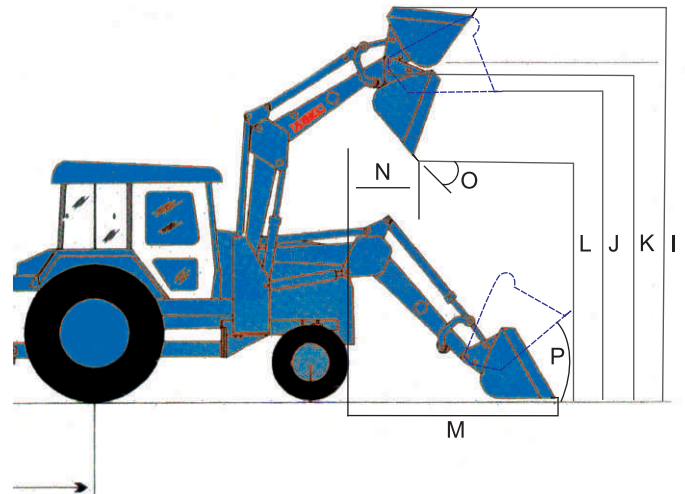

Action Construction Equipment Ltd.

Marketing Head Office

Jajru Road, 25 Mile Stone, Mathura Road,
Ballabgarh - 121004 (Haryana)
Ph. : +91-129-2306111,
E-mail : marketingtd@ace-cranes.com



Authorised Dealer

Note: In view of policy of continuous improvements, technical specifications can be varied without prior information. For detailed knowledge, please consult ACE marketing or Authorized Dealer. Accessories shown are not part of the standard equipment.

